

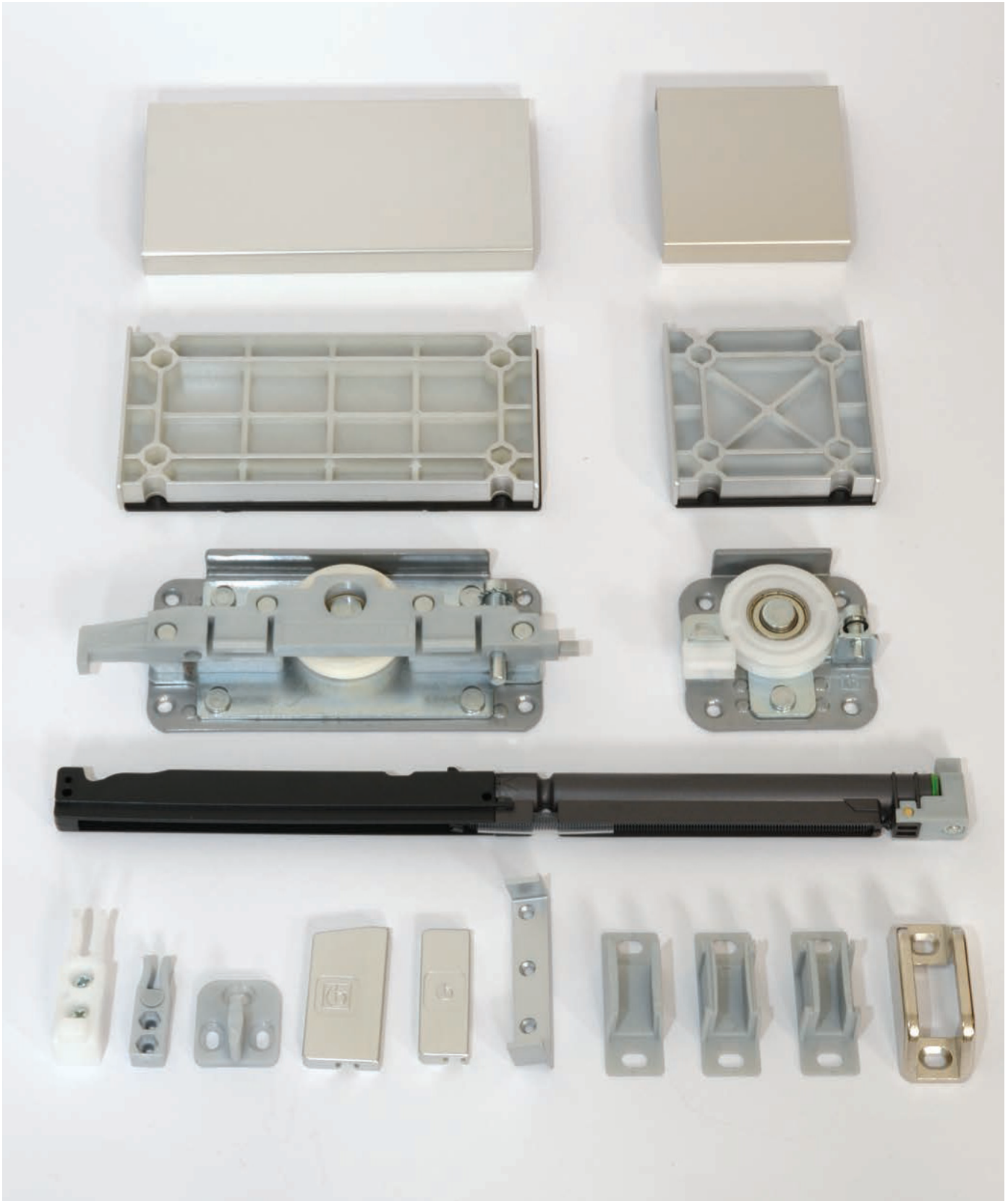

Diva Air

Innovative sliding system with amortised stopper for wooden doors.
Exposed sliding track.



ACCESSORIES

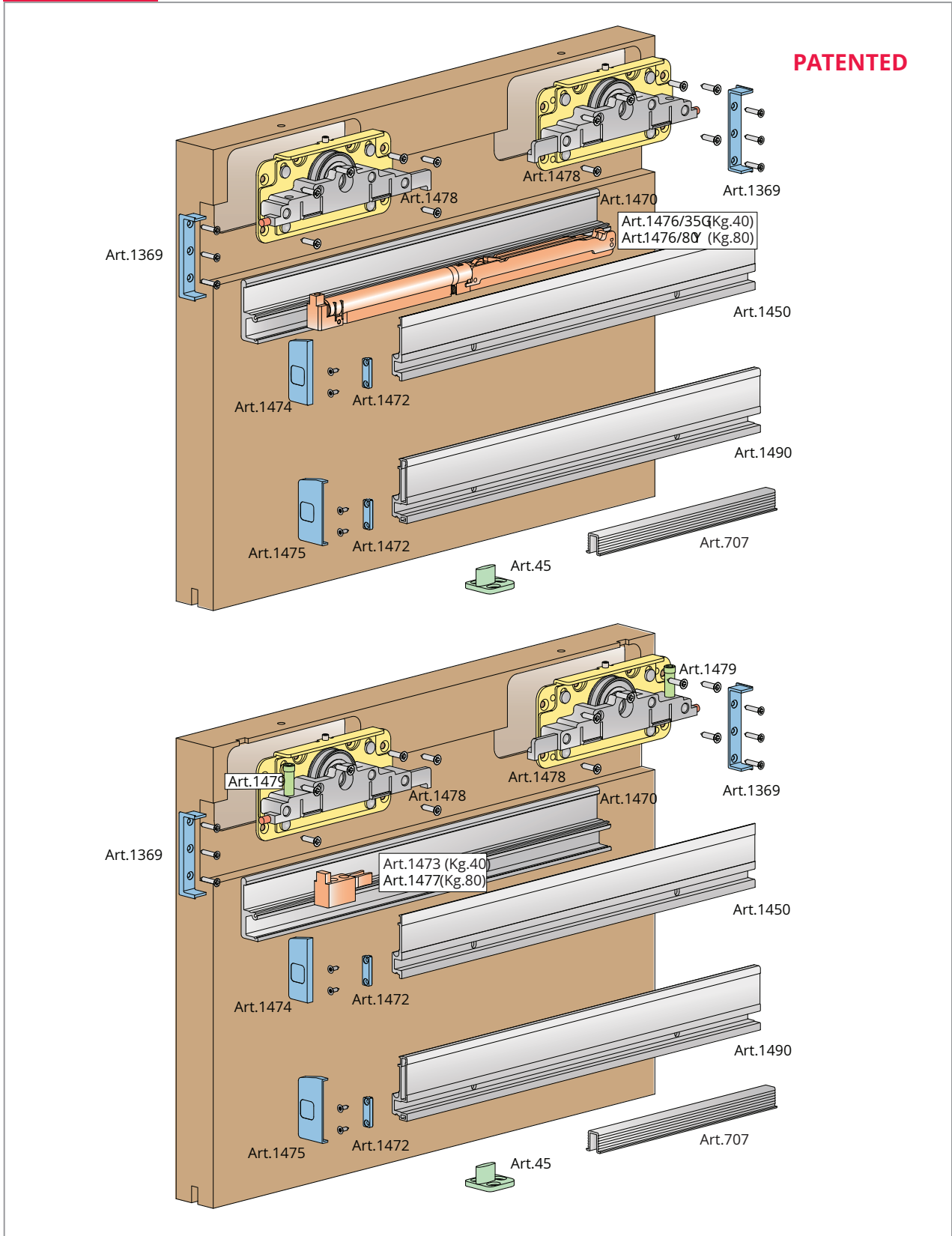

KIT

DOOR WITH SOFT CLOSING 40 Kg	<p>ART.1478/35G/12A ART.1478/35G/12AL ART.1478/35G/12N</p>
	<p>ART.1478/35G/18A ART.1478/35G/18AL ART.1478/35G/18N</p>
DOOR WITH SOFT CLOSING 80 Kg	<p>ART.1478/80Y/12A ART.1478/80Y/12AL ART.1478/80Y/12N</p>
	<p>ART.1478/80Y/18A ART.1478/80Y/18AL ART.1478/80Y/18N</p>
DOOR WITH CLASSIC STOPPER 40 Kg	<p>ART.1478/1473/12A ART.1478/1473/12AL ART.1478/1473/12N</p>
	<p>ART.1478/1473/18A ART.1478/1473/18AL ART.1478/1473/18N</p>
DOOR WITH CLASSIC STOPPER 80 Kg	<p>ART.1478/1477/12A ART.1478/1477/12AL ART.1478/1477/12N</p>
	<p>ART.1478/1477/18A ART.1478/1477/18AL ART.1478/1477/18N</p>

ACCESSORIES

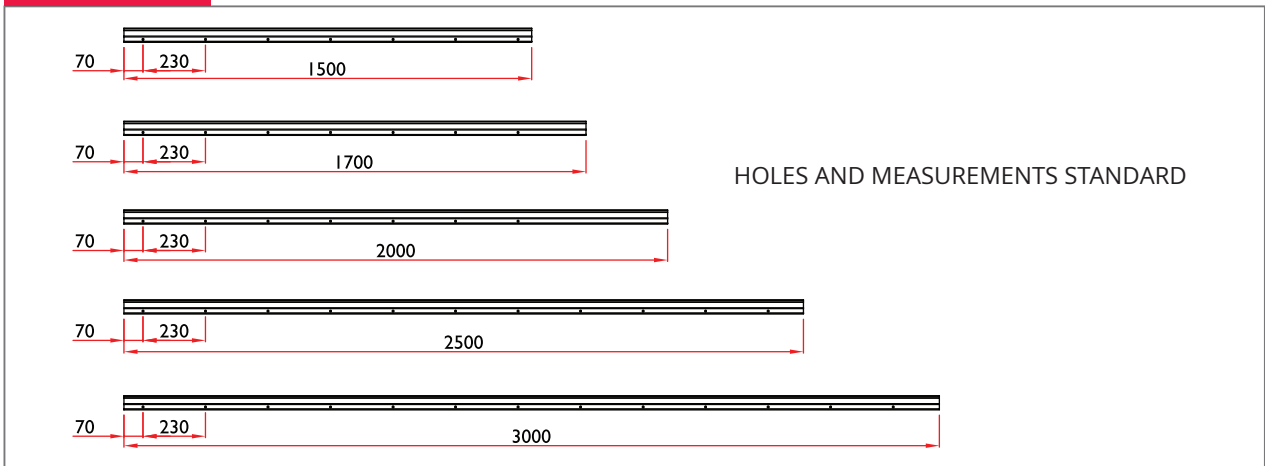

HOLES AND MEASUREMENTS STANDARD

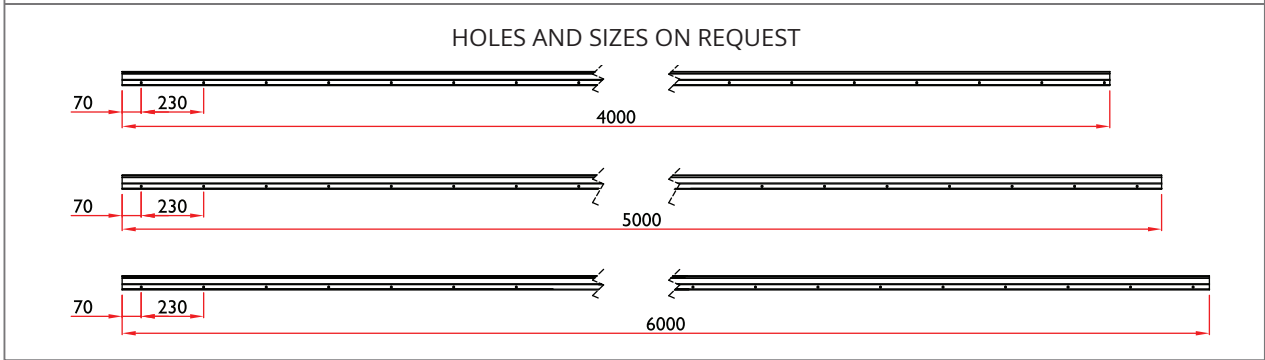

HOLES AND SIZES ON REQUEST

Specify article number, length and color when ordering



Art.1470



Art.1490



Art.1450

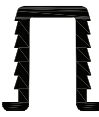

Art.707

A = Anodized silver
 B = Anodized bronze
 N = Electricolor black
 E3 = Electricolor 3 (Coffee)
 AL = Polished steel
 AT = Titanium steel

Kit P.V.C. rigido

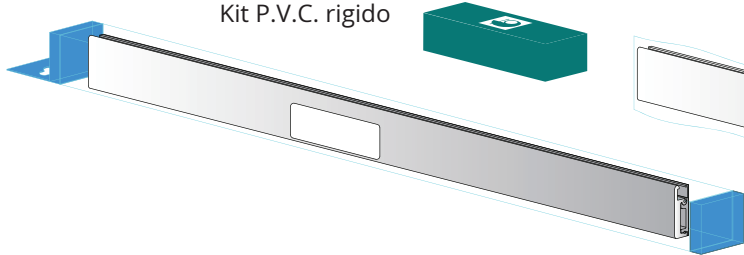

Kit Polytene

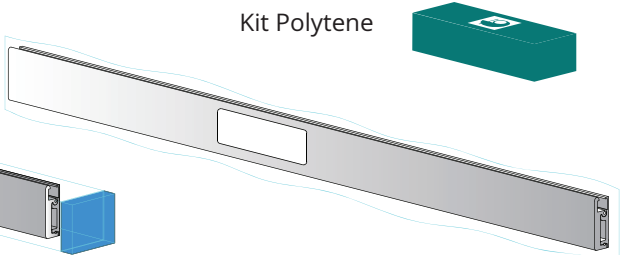

The pair of tracks can be requested packed in blister pack (P.V.C. rigido o Polytene).
Specify length, Color and Article number

DESCRIPTION OF UPRIGHTS

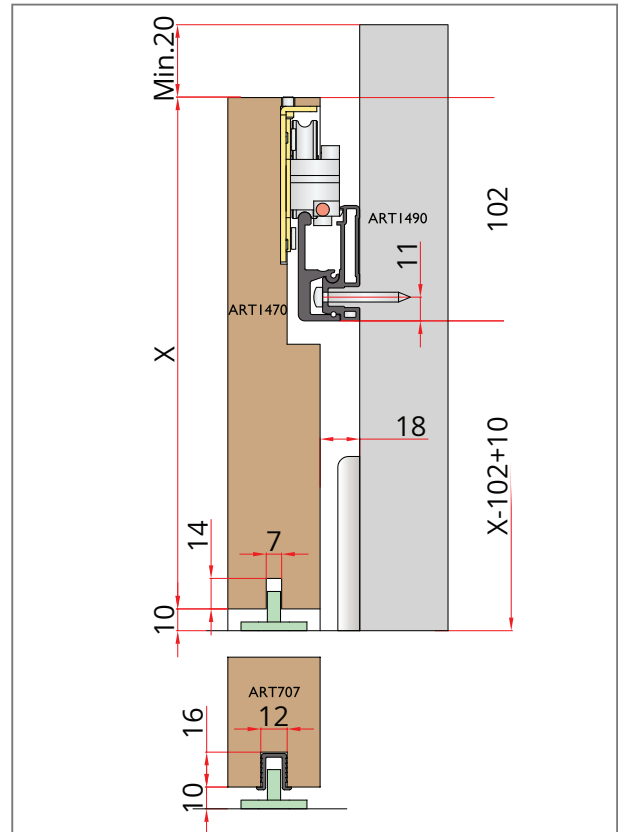
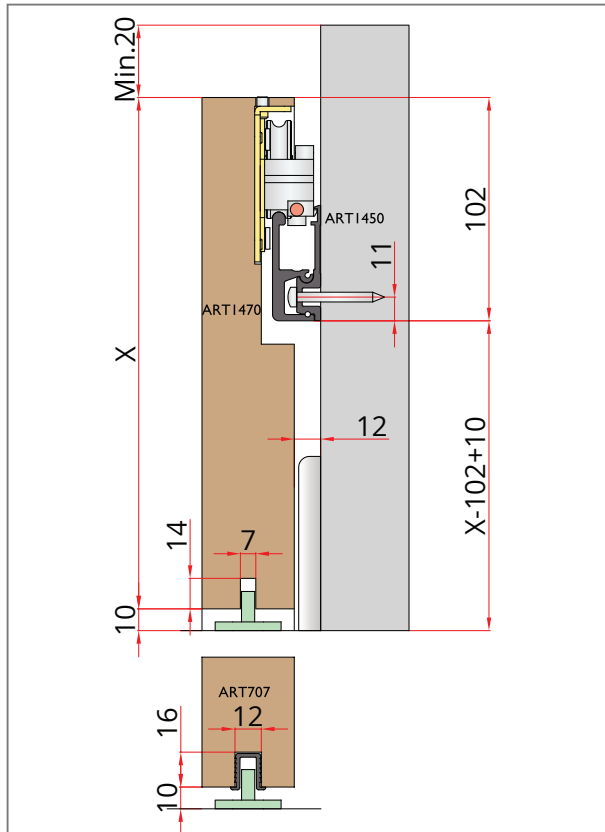

Specify the type of upright bar needed when ordering, based on the space desired between door panel and wall.

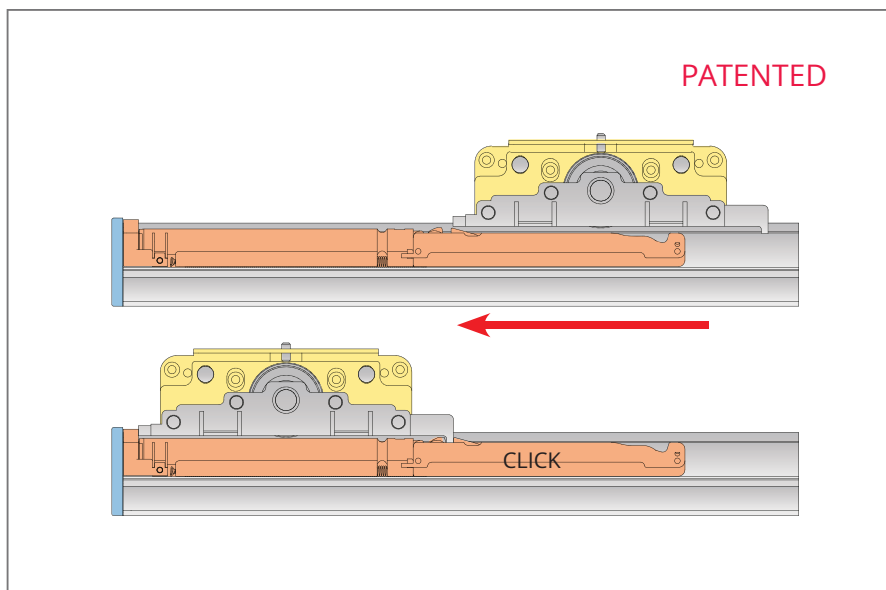

The shock absorber in the track calibrates itself automatically when the door panels close for the first time.

DESCRIPTION OF UPRIGHTS INSTALLATION

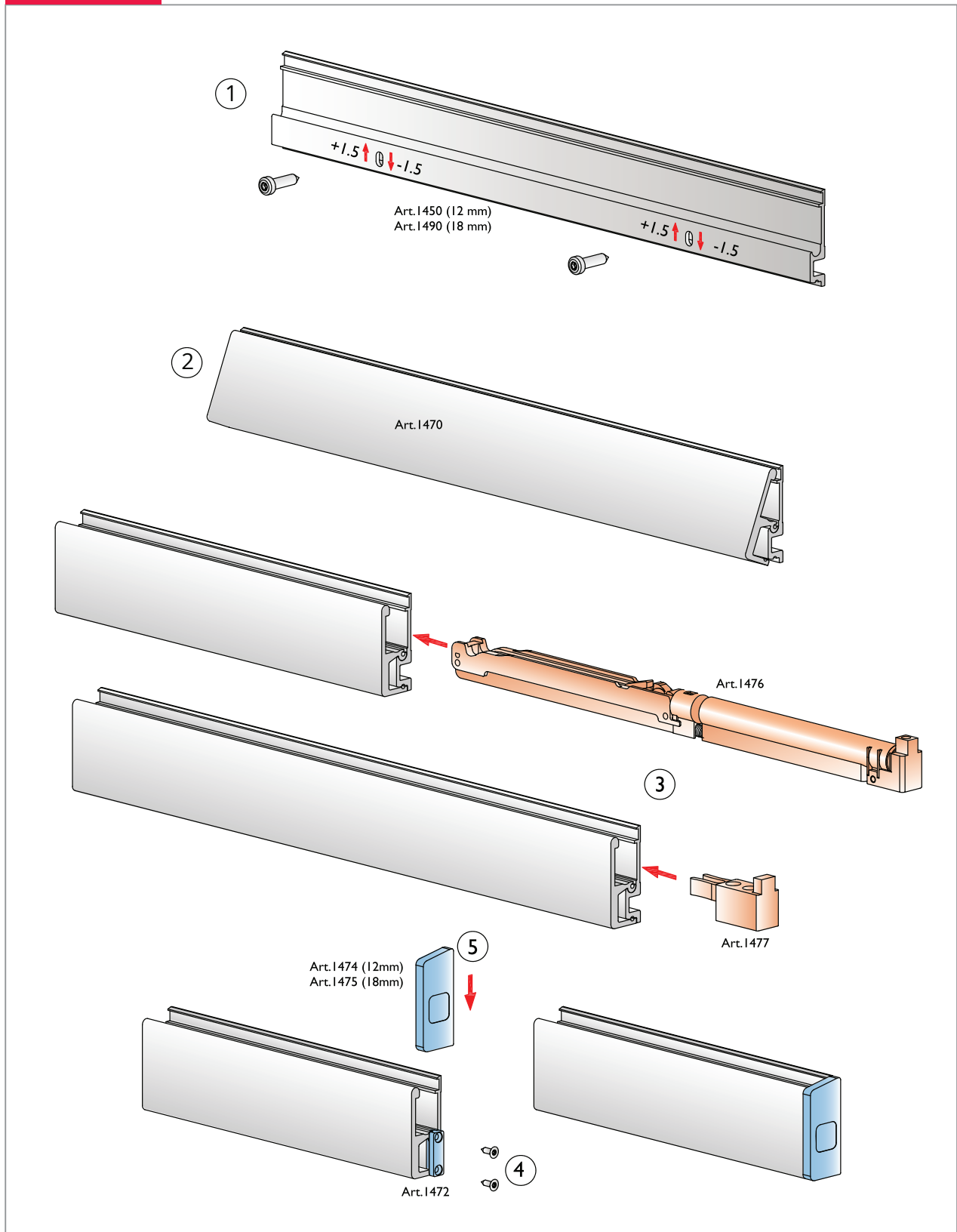

MANUFACTURE

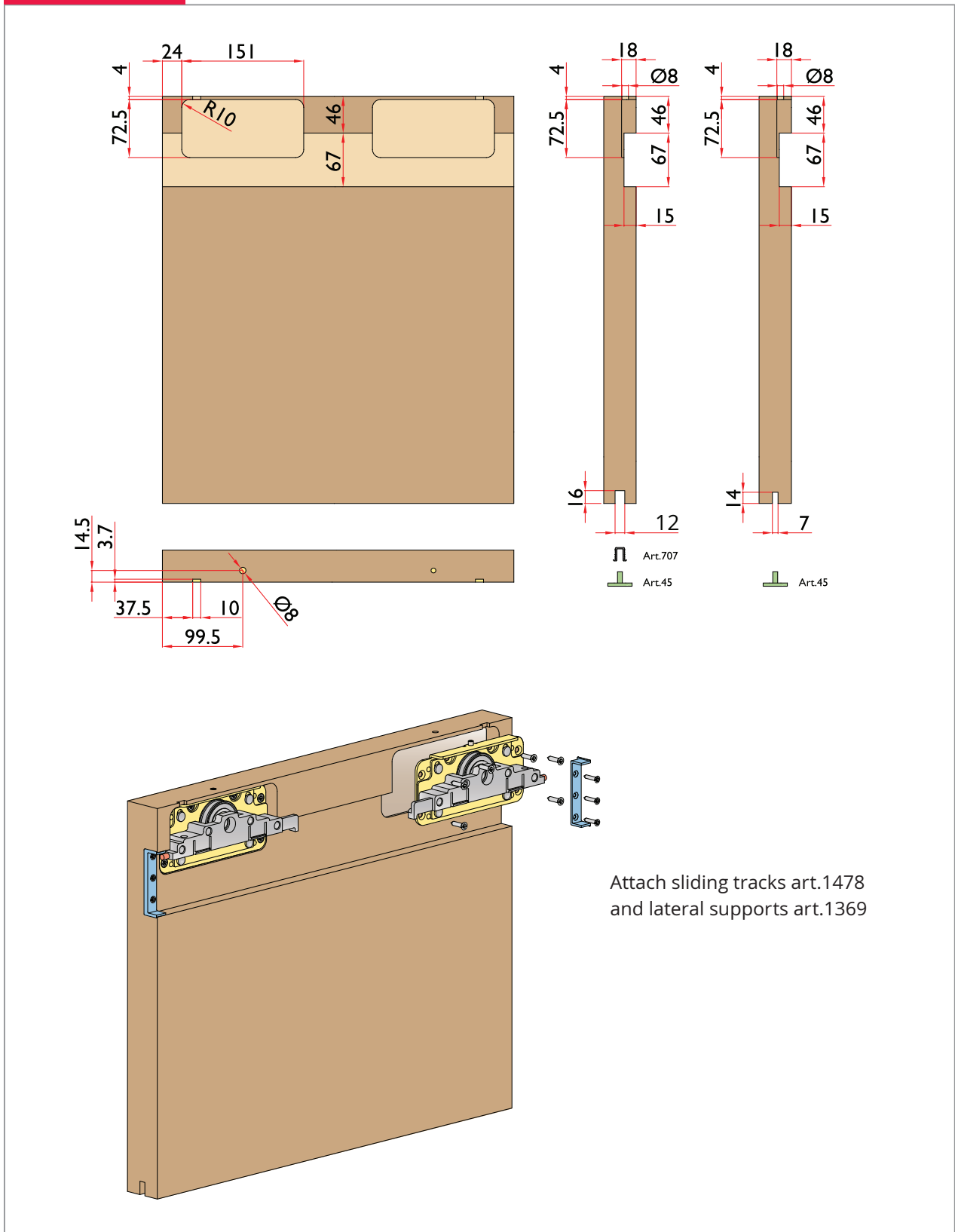

Attach sliding tracks art.1478 and lateral supports art.1369

MOUNTING OF THE ACCESSORIES

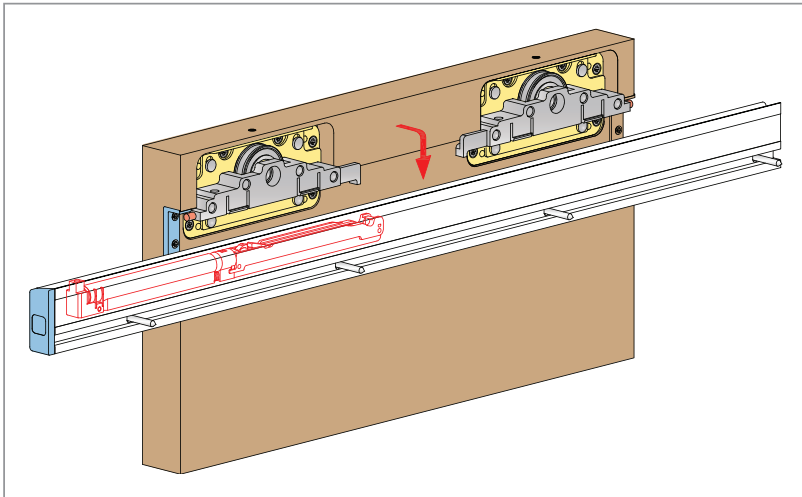

Hook the door panel onto the track

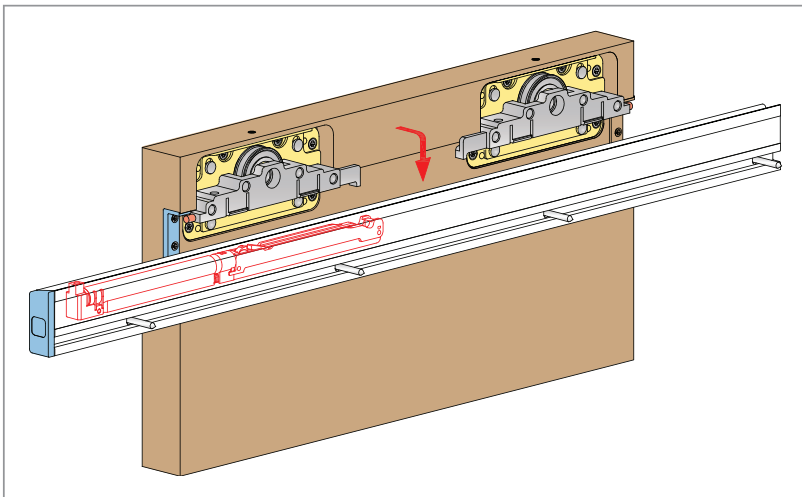

Regulate the sliding mechanism at point B

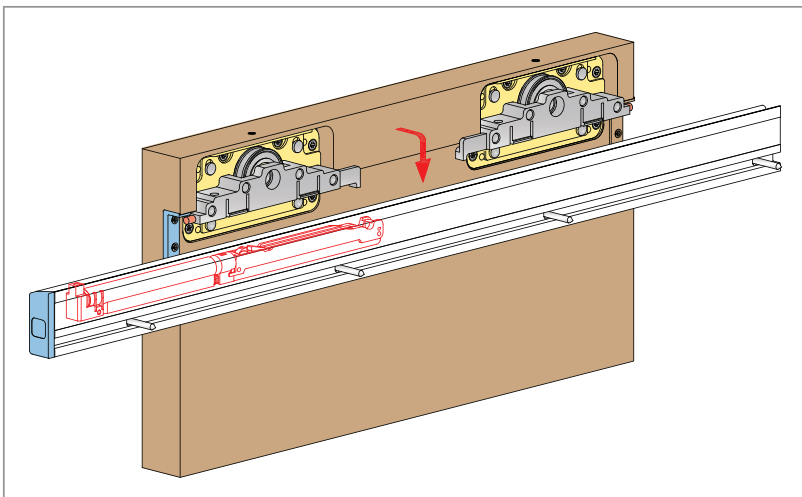

Tighten the screw art. 1479 at point A, for stops art. 1477 - 1473. Regulate the sliding mechanism at point B

DOUBLE DOOR

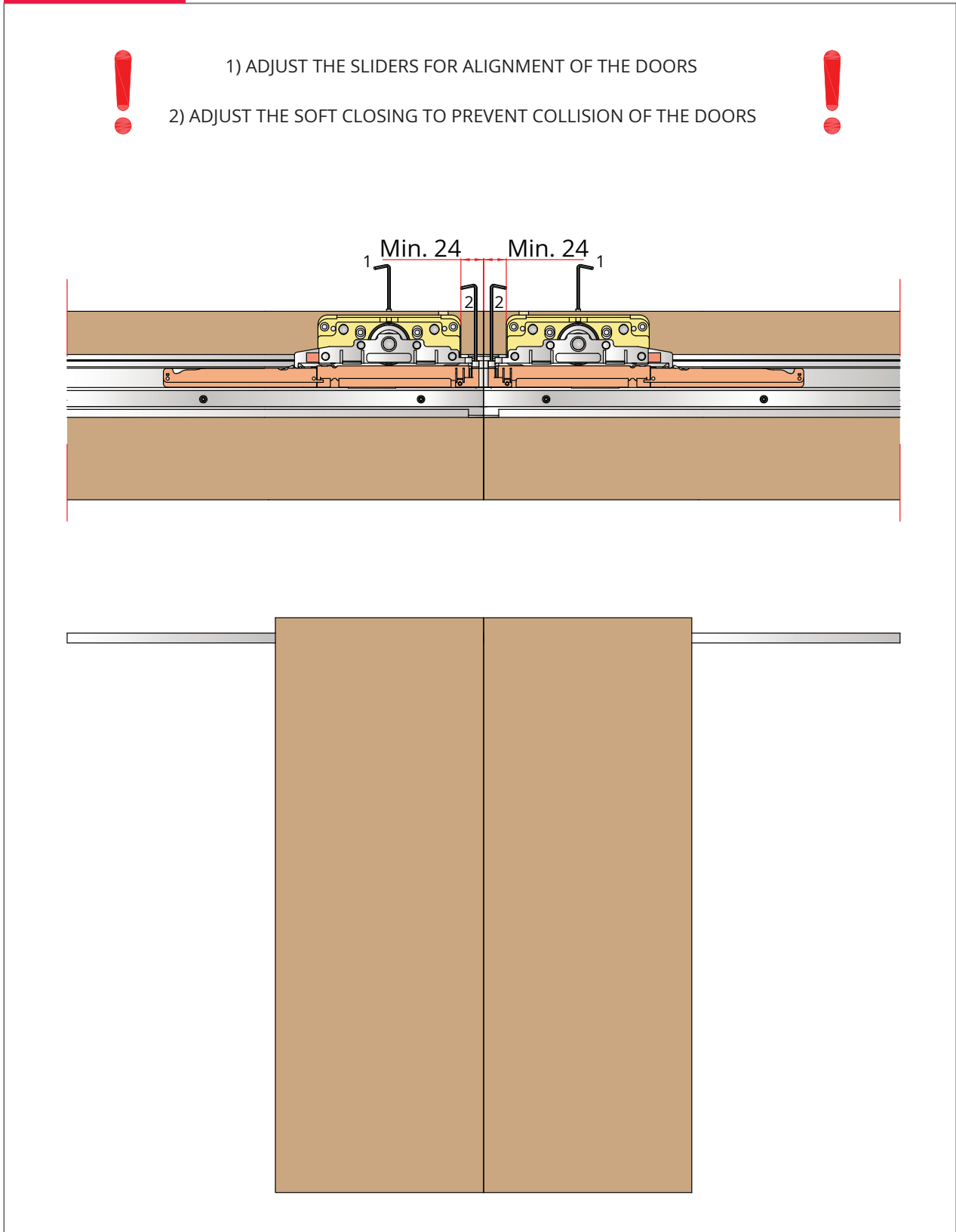

POSITIONING OF WALL MOUNTED TRACKS

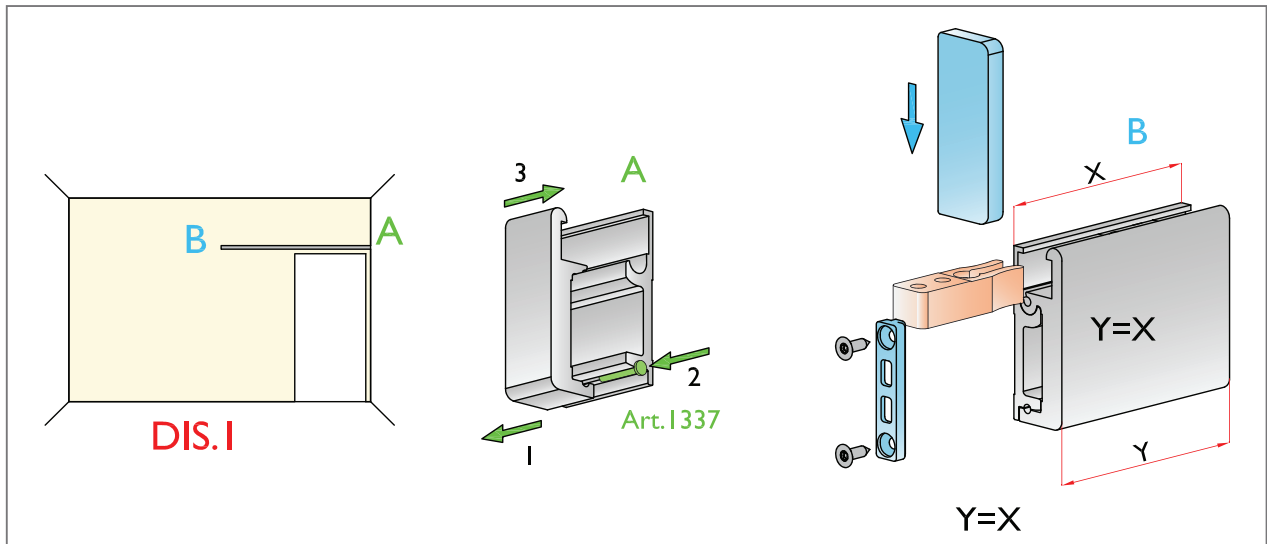

DIS 1: Applies to articles 1340 - 1350 - 1352 - 1351 with stop 1344 for Diva model and articles 1450 - 1470 - 1490 with stop 1473/1476 for Diva Air model

DIS 2 OPTIONAL: Applies to articles 1340 - 1350 - 1352 - 1351 with stop 1344 for Diva model and articles 1450 - 1470 - 1490 with stop 1473/1476 for Diva Air model

